

Model 4 Basket Strainer and Bag Filters

Strainers or Bag Filters:
Your Choice!

Model 4 strainer/filter housings are made in 2 sizes and 4 pressure ratings. In all cases, covers are easily removed without special tools, and the basket or bag is easily cleaned or replaced.

Features

- Low pressure drops
- Permanently piped housings
- Covers are O-ring sealed
- Carbon steel, or stainless steel (304 or 316) construction for housings
- All housings are electropolished to resist adhesion of dirt and scale
- Easy to clean!
- Adjustable-height legs, optional
- O-ring seals: Buna N, EPR, Viton®, Teflon®
- ASME code stamp available on select models
- Liquid displacers for easier servicing
- Four pressure ratings: 200 psi (with clamp cover) and 150, 300, or 500 psi (with eyenut cover)
- Duplex units are available
- Pipe sizes 3/4 thru 2-inch, NPT or flanged (standard 150 class flange)
- Two basket depths: 6, or 12 inches (nominal)

Options

- Bag filter hold-down devices
- Sanitary construction
- Different outlet connections
- Higher pressure ratings
- Extra-length legs
- Heat jacketing
- Epoxy coating
- Displacers
- Magnets



Covers are secured by three eyenut assemblies. One of them acts as a hinge, when the cover is opened.

Choosing A Basket Strainer Or Bag Filter

Choose between straining (removing particles down to 74 micron size) or filtering a fluid (removing particles down to 1 micron). This will direct you to choose the correct basket when ordering.

Operation

Unfiltered liquid enters the housing above the bag or basket and passes down through them. Solids are contained inside the bag or basket, where they're easily and completely removed when the unit is serviced.

Fluid bypass around the basket is prevented because the outside diameter of the filter bag seals radially against the housing inside diameter. A single cover gasket is used to seal the opening, and covers can be installed and removed without tools.

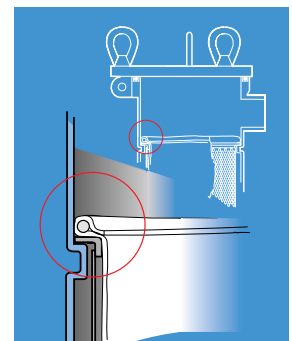

Pressure Drop Data

Basket strainers and bag filters are usually selected so that the pressure drop does not exceed 2 psi, when they are clean. Higher pressure drops may be tolerated, when contaminant loading is low. Bag change-out should occur at 15 psid.

The pressure drop data is accurate for all housings with strainer or bag filter baskets. When bag filters are added, total pressure drop becomes the sum of the pressure drop as determined by the steps below.

Follow these easy steps:

1. Using the desired pipe size and approximate flow rate, determine the basic pressure drop from the appropriate graph.
2. Multiply the pressure drop obtained in step 1 by the viscosity correction factor found in the accompanying table. This is the adjusted (clean) pressure drop for all baskets, without filter bags.
3. Add the pressure drop for the bag filter.

Note: Filter bags are specified separately. See page 106-109.

	1 (H ₂ O)	Viscosity, cps							
		50	100	200	400	600	800	1000	2000
Bag Style and All unlined baskets	.65	.85	1.00	1.10	1.20	1.40	1.50	1.60	1.80
40-mesh lined	.73	.95	1.20	1.40	1.50	1.80	1.90	2.00	2.30
60-mesh lined	.77	1.00	1.30	1.60	1.70	2.10	2.20	2.30	2.80
80-mesh lined	.93	1.20	1.50	1.90	2.10	2.40	2.60	2.80	3.50
100-mesh lined	1.00	1.30	1.60	2.20	2.40	2.70	3.00	3.30	4.40
200-mesh lined	1.30	1.70	2.10	3.00	3.40	3.80	4.40	5.00	6.80

Basket Data

Depth Nominal (inches)	Diameter (inches)	Surface Area (sq. ft.)	Volumn (cu. in.)	Bag Size No.
6	3.9	0.5	65	3
12	3.9	1.0	130	4

Model 4—For flow rates to 50gpm*



Clamp covers to the left and center, and eyenut cover to the right.

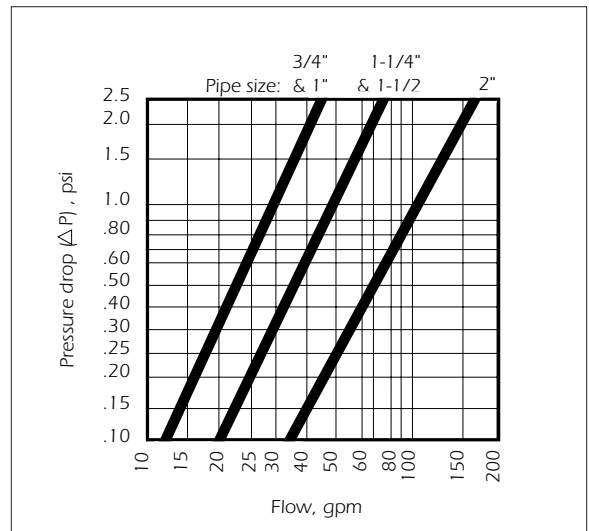

*Based on housing only. Fluid viscosity, bag filter used, and expected dirt loading should be considered when sizing a filter.

Dimensions (IN)

Cover Types

EYENUT COVER

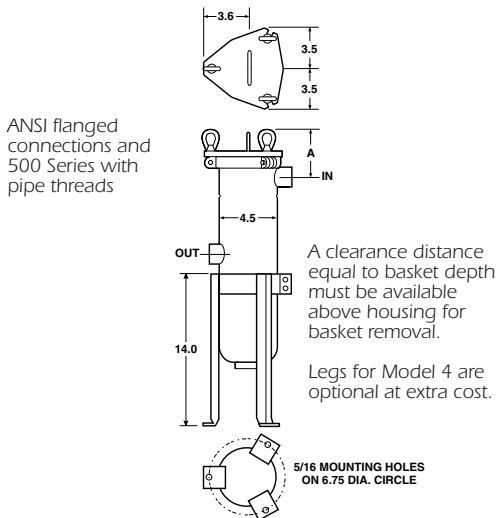

CLAMP COVER

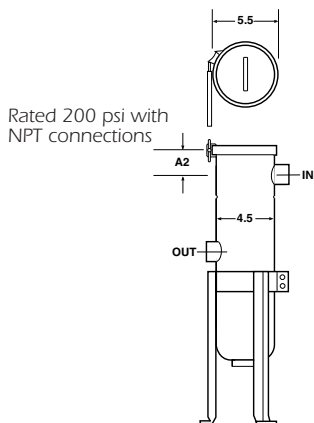

Outlet Styles

Flanged
(150 lb. ANSI)

Threaded
(NPT)

STYLE 1

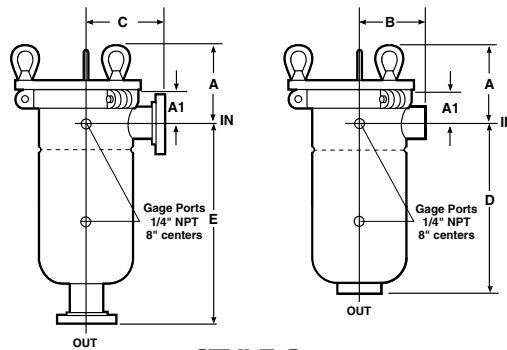

STYLE 2

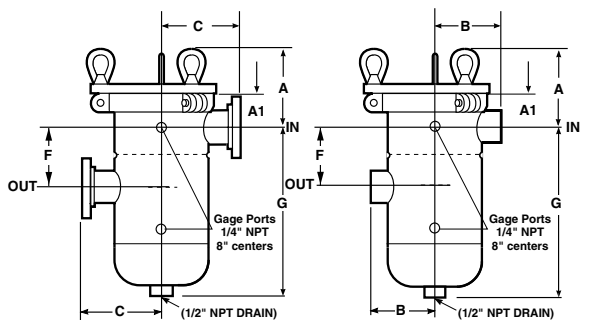

STYLE 3

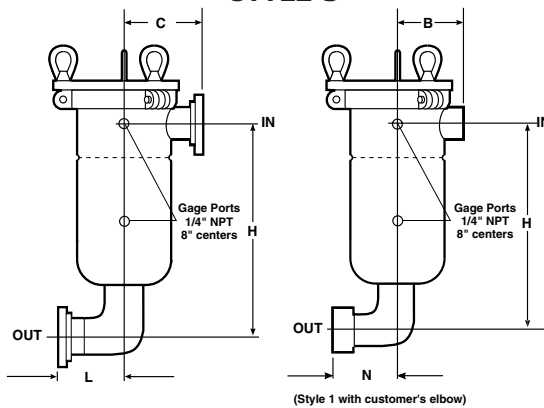

Dimensions (IN)

Model	Pipe Size	A	A1	A2	B	C	D	E	F	G	H	L	N
4-6	3/4	5.5	1.9	2.3	3.5	5.0	10.0	12.0	4.5	10.1	10.5	4.0	2.0
	1	5.5	1.9	2.3	3.5	5.0	10.0	12.0	4.5	10.1	10.9	4.0	2.5
	1-1/4	6.1	2.5	2.9	3.5	5.0	9.4	12.0	4.5	9.5	10.6	4.0	2.9
	1-1/2	6.1	2.5	2.9	3.5	5.0	9.4	12.0	4.5	9.5	10.9	4.0	3.3
	2	6.1	2.5	2.9	3.5	5.0	9.3	12.0	4.5	9.5	11.6	5.0	4.0
4-12	3/4	5.5	1.9	2.3	3.5	5.0	16.0	18.0	4.5	16.1	16.5	4.0	2.0
	1	5.5	1.9	2.3	3.5	5.0	16.0	18.0	4.5	16.1	16.9	4.0	2.5
	1-1/4	6.1	2.5	2.9	3.5	5.0	15.4	18.0	4.5	15.5	16.6	4.0	2.9
	1-1/2	6.1	2.5	2.9	3.5	5.0	15.4	18.0	4.5	15.5	16.9	4.0	3.3
	2	6.1	2.5	2.9	3.5	5.0	16.3	18.0	4.5	15.5	17.6	5.0	4.0

